

Hydraulic separator XP 80 - DN 32 ELEC

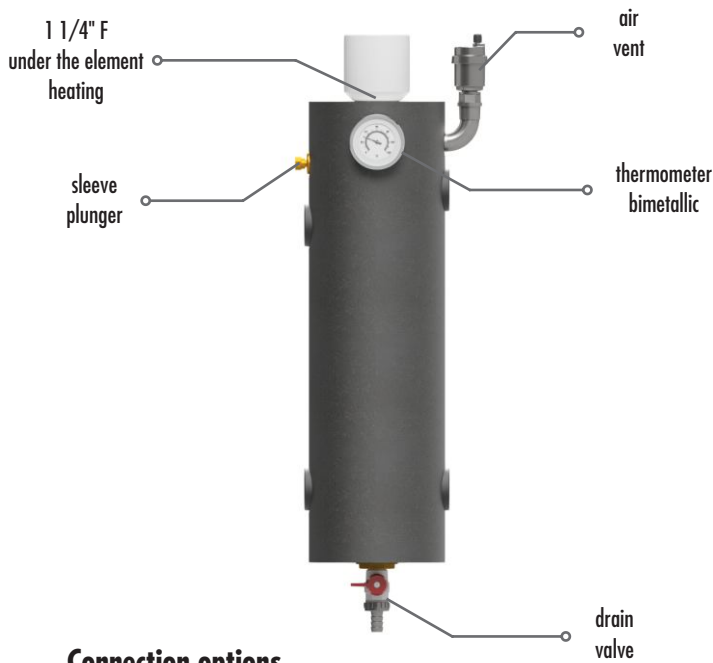

Hydraulic separator **XP 80 - DN 32 ELEC** for heating systems is made of steel. The factory is equipped with an automatic air vent, an immersion sleeve for connecting a temperature sensor, drain valve and EPP insulation. The hydraulic clutch **XP 80 ELEC** will prove itself in systems powered by a heat pump or a fireplace as an additional source of heat. Additionally, anti-freezing agent can be used in the installation of summer houses or buildings used occasionally.

Attention! The product does not contain a heater.

Attention! To prevent damage to the heating element during operation, a constant flow of medium through the device must be ensured.

Connection options

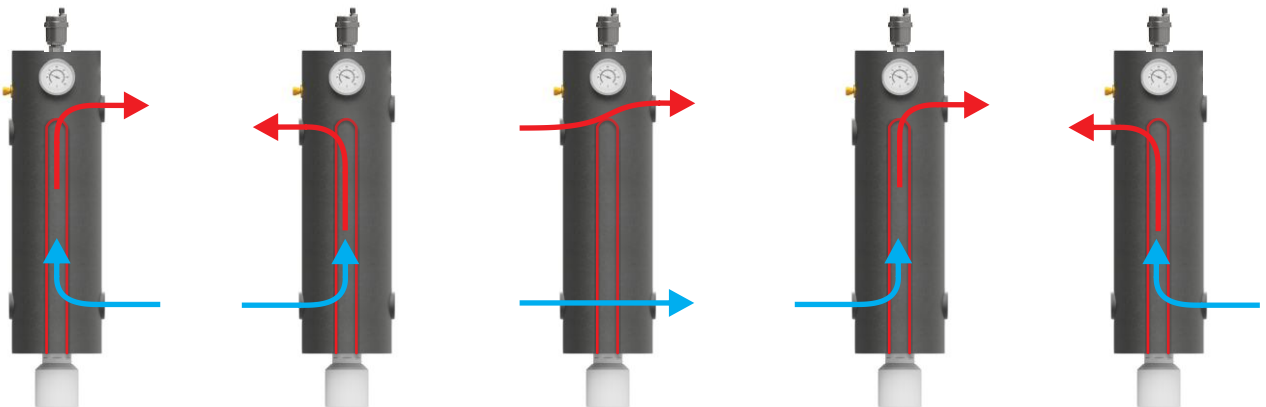

Possibility of mounting the device



The XP 80 ELEC low loss header should only be used in central heating systems.



It is important that the coupling is filled with the heating medium before starting work.



The heating device should be installed in accordance with the manufacturer's instructions.



A circulation pump must be installed for the correct operation of the device.

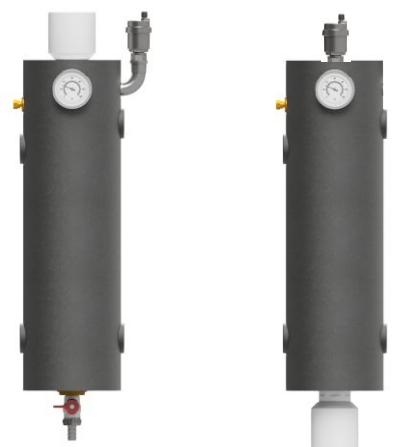

Dimensions:

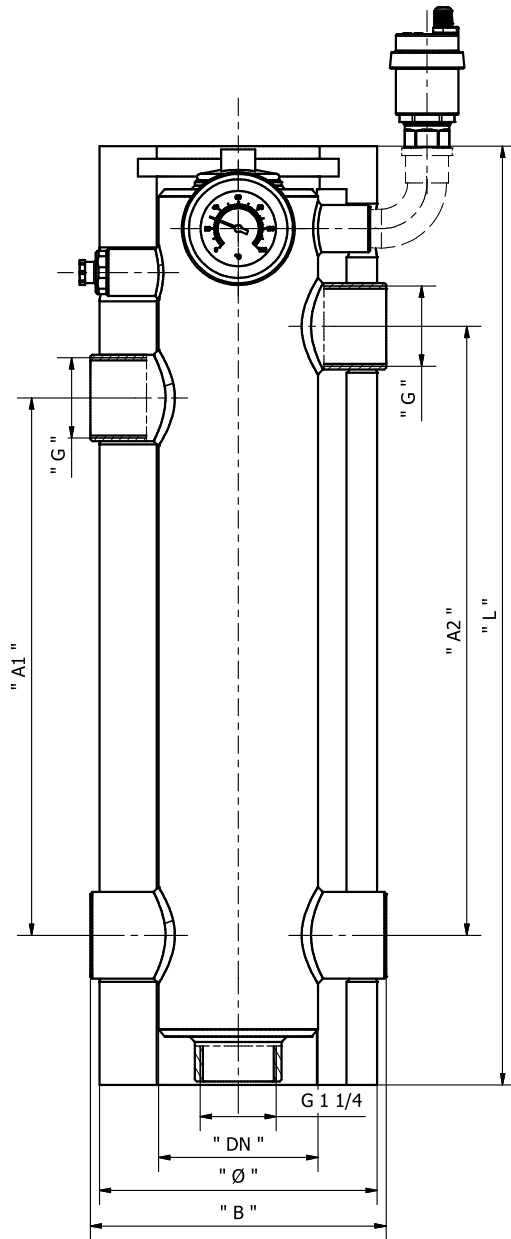

	XP 80 - DN 32	XP 100 - DN 40
A1	300	300
A2	340	340
B	160	195
Ø	155	190
L	520	520
DN	80	100
G	1 1/4" F	1 1/2" F